



CHAMBER VACUUM PACKAGING MACHINE

TRAY SEALERS

VACUUM SHRINK COMBINATIONS

THERMOFORMER



More information about the machines with application examples and films can be found on our free multimedia CD.



Sous-Vide – Cooking in vacuum!
Please find further information on our free DVD. Please request our DVD.

TABLE MODELS



TOPVAC



VACUBOY



NIKIVAC



PLUSVAC 20

W 1



W 2



Technical detail	TOPVAC	VACUBOY	NIKIVAC	PLUSVAC 20	W 1	W 2
Chamber size (w x l x h/mm):	265 x 350 x 90	360 x 380 x 140	430 x 400 x 160	430 x 505 x 175	-	-
Sealing length (mm):	250	350	405	1 x 405 (2 x 405)	-	-
Distance x(y)/(mm):	300	340	350	455 (400)	-	-
Vacuum pump (cbm/h):	6	10	16	21	-	-
Power connection:	230V/1Ph+N+PE/50Hz	230V/1Ph+N+PE/50Hz	230V/1Ph+N+PE/50Hz	400V/3Ph+N+PE/50Hz	-	-
Power (kW):	0,3	0,63	0,83	starting at 1	-	-
Maximum bag (mm):	250 x 350	350 x 400	400 x 400	400 x 500	-	-
Outer dimension (mm):	315 x 500 x 300	400 x 500 x 360	490 x 540 x 400	480 x 655 x 385	500 x 620 x 620	500 x 620 x 770
Weight (kg):	25	40	60	70	20	35



FLOOR MODELS



More information about the machines with application examples and films can be found on our free multimedia CD.

PLUSVAC 21



PLUSVAC 23
PLUSVAC 24
PLUSVAC 27



S 501



SHRINK TANK

ST 75

Technical detail

Water contents (l):	70
Maximum weight of product (kg):	20
Working area (mm):	600 x 375
Dipping depth (mm):	220
Power connection:	400/3
Power (kW):	9,3
Safeguard (Amp.):	25
Outer dimension (w x l x h/mm):	695 x 630 x 1315 (2150)
Weigh (kg):	115 (135)



Technical detail	PLUSVAC 21	PLUSVAC 23	PLUSVAC 24	PLUSVAC 27	S 501
Chamber size (w x l x h/mm):	430 x 505 x 175	445 x 585 x 190	640 x 480 x 200 (250)	640 x 480 x 167	895 x 565 x 230
Sealing length (mm):	1 x 405 (2 x 405)	1 x 420 (2 x 420)	2 x 455	2 x 620	1 x 455 (2 x 455) + 1 x 740
Distance x(y)/(mm):	455 (400)	530 (485)	(540)	(380)	765 (480)
Vacuum pump (cbm/h):	21 (40)	40 (63)	40 (63)	40 (63)	100 (160)
Power connection:	400V/3Ph+N+PE/50Hz	400V/3Ph+N+PE/50Hz	400V/3Ph+N+PE/50Hz	400V/3Ph+N+PE/50Hz	400V/3Ph+N+PE/50Hz
Power (kW):	starting at 1 (1,5)	starting at 1,5 (2)	1,5 (2)	1,81 (2,26)	3,5 (5,5)
Maximum bag (mm):	400 x 500	420 x 600	450 x 600	600 x 400	450 x 800
Outer dimension (mm):	480 x 655 x 975	500 x 770 x 1000	710 x 665 x 1010	710 x 665 x 1010	975 x 750 x 1170
Weight (kg):	65 (95)	110 (125)	115 (130)	145 (150)	280 (400)



DOUBLE CHAMBER MODELS



Sous-Vide – Cooking in vacuum!
Please find further information on our free DVD. Please request our DVD.

PLUSVAC 26



PLUSVAC 25



SD 320
SD 520



SD 1000



Technical detail	PLUSVAC 26	PLUSVAC 25	SD 320	SD 520	SD 1000
Chamber size (w x l x h/mm):	430x505x175	640 x 480 x 200 (250)	585 x 725 x 225	800x730x250	1160x1160x150 (280)
Sealing length (mm):	2 x 405 (4x405)	4 x 455	2 x 455 (4 x 455)	2 x 660 (4x660)	4 x 1080
Distance x(y)/(mm):	455 (400)	(540)	640 (585)	730 (660)	(925)
Vacuum pump (cbm/h):	40 (63)	63 (100)	63 (100, 160)	160 (250)	1 x 250 (2 x 250/1 x 250 + 1 x 500)
Power connection:	400V/3Ph+N+PE/50Hz	400V/3Ph+N+PE/50Hz	400V/3Ph+N+PE/50Hz	400V/3Ph+N+PE/50Hz	400V/3Ph+N+PE/50Hz
Power (kW):	starting at 1,5 (2)	2,5 (3,2)	starting at 2,5 (3,2 / 5)	starting at 5,5 (7,5)	11,6 (13,3/17,7)
Maximum bag (mm):	400x500	450x600	450x700	650x800	1050x1200
Outer dimension (mm):	955 x 655 x 985	1400 x 665 x 1010	1300 x 960 x 1200	1620 x 1020 x 1150	2480 x 1460 x 1650 (1780)
Weight (kg):	150 (160)	260 (280)	390 (410)	610 (680)	1400 (1700)



TRAY SEALERS



More information about the machines with application examples and films can be found on our free multimedia CD.

RAPIDPAC

Using the KOMET RapidPac it is possible to manufacture products in advance and to package them under modified atmosphere (only CO₂/N₂). This new technology including the used trays and films provides a considerably longer durability of the product compared to the usage of conventional packaging procedures.

The KOMET RapidPac can also be equipped with a laser perforated top film. This new top film allows evenly heating up the product within seconds without drying it out due to the generated overpressure when regenerating the food. By using this treatment it is possible to achieve a better cook balancing which would contrary not be possible when heating up the product openly due to the different heating up times of the versatile products.

RapidPac E with changeable frame system

Because of the changeable frame, the use of divided trays (see pictures) for 137 x 187 mm and 178 x 227 mm and now new for 160 x 205 mm and 162 x 265 mm (1/4 GN) as standard tray sizes is possible.

RapidPac ES with changeable frame system

Machine will be made especially according to your tray size and requested format. Maximum dimensions 178 x 265 mm.

RapidPac with fixed frame

The well known machine with fixed frame. Available for trays 137 x 187 mm or 178 x 227 mm.



RAPIDPAC

Changeable frame system:



Technical detail RAPIDPAC

Top film for tray 137 x 187 (mm):	190
Top film for tray 160 x 205 (mm):	208
Top film for tray 178 x 227 (mm):	230
Top film for tray 162 x 265 (mm):	268
Maximum tray depth (mm):	65
Outer dimensions (w x l x h/mm):	330 x 560 x 550
Maximum diameter of top film (mm):	200
Power connection:	230V/1Ph+N+PE/50 Hz
Power (kW)	0,9
Weight (kg):	37

Standard Equipment

- Semi-automatic packing using preformed trays with sealable top film and gas flushing/MAP
- Stainless steel casing
- User friendly and easy to use machine
- Easy, manual insertion of the trays in the sealing frame

- One tray per cycle
- Sealing plate is temperature-controlled and Teflon-coated

Options

- Cart W1/W2
- Special voltages

Standard tray sizes (mm)

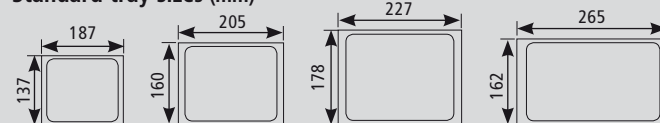

* On request we can send you a list of the useable trays and suppliers.



TRAY SEALERS



TS 100

The TS 100 is a professional, semi-automatic stand-alone tray sealing machine with vacuum and gas flushing (MAP) – also suitable for gas flushing with oxygen (optional). It ensures an optimal shelf life for the packed products with minimal gas usage. Offer your customers a fresh packing service and watch your sales grow.

The KOMET TS 100 can also be equipped with a laser perforated top film. This new top film allows evenly heating up the product within seconds without drying it out due to the generated overpressure when regenerating the food. By using this treatment it is possible to achieve a better cook balancing which would contrary not be possible when heating up the product openly due to the different heating up times of the versatile products. This laser perforated top film can only be used for gas CO₂/N₂, and not for O₂, Gas!



TS 100

Product characteristic

- Semi-automatic packing with prefabricated trays with a sealable top film without vacuum or under vacuum with gas
- User-friendly, problem-free conversion to other additional tools
- Automatic film winding
- Vacuum pump built into mobile casing and protected against spraying water
- Automatic contour cut around each tray
- Manual insertion of the trays under the sealing tool, after which the trays are automatically vacuumed, gas-flushed, sealed and cut
- Compressed air sealing with high seal strength
- Filling plates for the vacuum chamber, achieving faster vacuuming and less gas usage.

Standard tray sizes (mm):

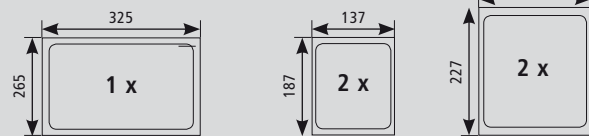

1/2 gastronorm single tool

double capacity tools

Technical details TS 100

Pump (cbm/h):	40 (63, 100)
Top film width (mm):	422
Film core diameter (mm):	70 – 76
Maximum tray depth (mm):	95 (150)
Outer dimensions (w x l x h/mm):	540 x 980 x 1500
Working height (mm):	970
Compressed air consumption (l/cycle):	6
Maximum diameter of top film (mm):	330
Power connection:	400V/3Ph+N+PE/50Hz
Power (kW)	starting at 3
Weight (kg):	235 (240, 260)

Important: Air pressure connection necessary!

Options

- Vacuum pump: 63 cbm/h or 100 cbm/h
- Compressed air generator with pressure compensation tank
- Special voltages on request
- Gasflushing with oxygen
- Maximum depth of tray: 150 mm
- Other tray sizes possible
- Right and left stainless steel shelves
- Gas bottle holder
- Film feed accurate to the millimetre, thereby reducing film usage
- Photo cell for printed film with print marks
- Switch to change between two gasbottles
- Pressure reducer for N₂/CO₂ or O₂



AUTOMATIC TRAY SEALERS



More information about the machines with application examples and films can be found on our free multimedia CD.

TS 1000

The TS 1000 fully automatic vacuum tray-sealing machine provides fast, economical and versatile packing in high quantities in a short period of time with vacuum, gas flushing (MAP) standard CO₂/N₂ (option O₂) or only simply sealing. If high volume has to be packed this is the right machine for you. Simply load the filling trays onto the in-feed conveyor, the rest is done automatically by the TS 01000. The trays are transported out of the machine after packing and can be labelled and weighed afterwards.

The KOMET TS 1000 can also be equipped with a laser perforated top film. This new top film allows evenly heating up the product within seconds without drying it out due to the generated overpressure when regenerating the food. By using this treatment it is possible to achieve a better cook balancing which would contrary not be possible when heating up the product openly due to the different heating up times of the versatile products. This laser perforated top film can only be used for gas CO₂/N₂ and not for O₂ Gas!



TS 1000

Important: Air pressure connection necessary!

Standard tray sizes (mm):

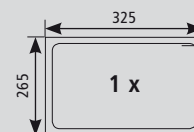

1/2 gastronorm single tool

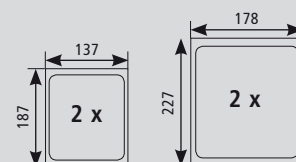

double capacity tools

Technical detail TS 1000

Pump Busch (cbm/h):	63
Maximum tray dimension:	370 x 350 x 120 mm
Top film width:	422 mm
Max. diameter of top film:	330 mm
Film core:	76 mm
Power connection:	400V/3Ph+N+PE/50Hz
Power (kW)	starting at 4
Compressed air consumption:	approx. 50 ltr./cycle at 6 bar
Speed:	6 cycles per minute, 360 cycles per hour
Loading station:	1250 mm, with 3 open spaces
Loading height:	950 mm
Height of exit conveyor:	950 mm
Outer dimensions:	3100 x 990 x 1950 mm
Weight:	approx. 1000 kg

Standard equipment

- Gas flushing (MAP)
- 63 cbm/h Busch pump
- Error message display on control board
- Contour cutting around each tray
- Filling plates for the vacuum chamber, resulting in faster vacuum times and less gas usage
- Integrated splash water resistant control box
- Teflonised and temperature controlled sealing plate
- 6 different transport speeds
- air welding with high seal strength
- High security because of security covers on all movable parts

- Impulse Vacuum
- compressed air and gas monitoring
- Easy slide switching
- Service program for film and tool change
- Pilz Safety

Options

- 100, 160 or 250 cbm/h pump
- Special voltage upon request
- Connection to scale and labeler
- Longer loading station
- Tray sizes upon request
- Die set with 1, 2 or 3 trays per cycle possible
- Photocell for printed top film



AUTOMATIC VACUUM PACKAGING MACHINE FOR SLICED PRODUCTS



FASTVAC

Fully automatic vacuum packaging machine Fast Vac for sliced and/or whole cuts with a maximum height of 20 mm. This In-line fully automatic packaging machine eliminates the costly labour of manually loading products into a bag. Another advantage is that during the whole process the product is not touched by hand and therefore much hygienic packed. The sliced or stacked product is introduced to the in-feed conveyor of the packaging machine, there it measures the length of the product in order to produce a bag the exact length of the product. Once in the chamber the product is vacuum packaged or as an option gas flushed (MAP) and transported automatically on to an exit conveyor – the cycle is complete. The final step of this process could include an automatic or manual weigh price labeler.



FASTVAC



Technical details FASTVAC

Pump Busch (cbm/h): 63
 Compressed air consumption (l/min): 6 with 6 bar
 Compressed air connection: 1/4"
 Gas connection: 1/4"
 Film width (mm): 322
 Film core (mm): 76
 Maximum core of top and bottom film (mm): 200

Weight (kg): 400 (420)
 Maximum Package dimension internal (mm): 240 x 250
 Maximum Package dimension external (mm): 260 x 270
 Cycle speed according to product (cycles/min): 3 – 5
 Height of infeed and exit conveyor (mm): 1000 ± 70
 Outer dimension (mm): 1360 x 780 x 1650
 Power connection: 400V/3 Ph+N+PE/50 Hz
 Power (kW): 4 (5)

Standard Equipment

- Air pressure sealing
- user friendly SPS sensor control

Options

- Gas flushing (MAP)
- Pump 100 cbm/h

Important: Air pressure connection necessary!



SINGLE CHAMBER WITH HOT WATER SHRINK TUNNEL



More information about the machines with application examples and films can be found on our free multimedia CD.

S 501 B + ST 170

S 501 B: Stainless steel construction. The chamber has 2 stainless steel sealing bars front 740 mm right 455 mm. Sealing with airpressure support. Cut-off sealing separately adjustable. The machine is complete with high efficiency vacuum pump 100 cbm/h, user friendly control board, automatic lid movement, conveyor with height adjustment, vacuum controlled by sensor and vacuum stop button. Following options are possible: gas flushing, bi-active sealing, footswitch, vacuum pump 160 cbm/h.

ST 170: Stainless steel construction. The automatic transport of the product in and out of the shrink tunnel is controlled by a photocell. Water temperature is adjusted with a thermostat. We also offer the following standard equipment: steam exhaust release through the lid, dipping time and dipping depth of water, also time for water to drip from product is adjustable, slight on left side, pneumatic dipping cylinder, automatic filling of water, user friendly construction, easy cleaning, manual dipping is possible, use of machine without dipping process is possible, dipping platform 820 x 450 mm and heating power 36 kW.



ST 170

S 501 B

Technical details

Chamber size (w x l x h/mm):	895 x 565 x 230
Usable chamber high (mm):	160
Sealing length (mm):	1 x 455 + 1 x 740
Distance x (y) (mm):	765 (480)
Vacuum pump (cbm/h):	160 (250)
Power connections:	
Power (kW):	400V/3PH+N+PE/50Hz
Compressed air (l/min):	5,5 (7,5)
Maximum bag (mm):	50 at 6 Bar
Outer dimensions (w x l x h/mm):	450 x 800
Weight (kg):	975 x 755 x 1170
Important:	approx. 380 (500) Air pressure connection necessary!

S 501 B

Technical details

Working area (w x l/mm):	820 x 450
Dipping depth (mm):	100/150/200
Water volume (l):	140
Maximum Product weight (kg):	50
Power connections:	400V/Ph3+N+PE/50Hz
Power (kW):	37
Safeguarding (Amp.):	63
Compressed air (l/min):	25 at 6 Bar
Outer dimensions (w x l x h/mm):	950 x 890 x 1500
Weight (kg):	265
Heating capacity (kW):	36

ST 170

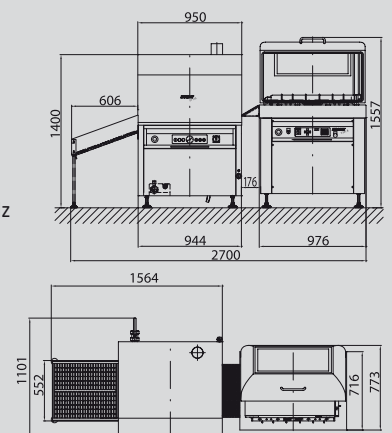

AUTOMATIC BELT VACUUM CHAMBER MACHINE



S 910 B + ST 170

New automatic vacuum chamber machine with conveyor belt constructed for packing a high capacity of small and large products. The operation method can be changed between „automatic“ and “manual“. For the automatic operation the S 910 B is equipped with 2 sealing bars each 1.000 mm long. For manual operation it is possible to add one more sealing bar with 530 mm for packing very long products up to 1 m. Therefore this machine can be used for every kind of use and product.

The vacuum pump is integrated in the machine for optimised protection. The cover movement and conveyor speed can be adjusted individually to the requests of the user and products. Because of this new solution your products can be vacuum packed very fast and economically with a minimum of personnel expense. The integrated discharge belt allows an automatic process of the packages afterwards e.g. shrinking, weighing, labelling etc.



ST 170: stainless steel construction. The automatic transport of the product in and out of the shrink tunnel is controlled by a photocell. Water temperature is adjusted with a thermostat.

- Steam exhaust release through the lid
- Dipping time and dipping depth of water, also time for water to drip from product is adjustable
- Slight on left side
- Automatic filling of water
- User friendly construction, easy cleaning
- Manual dipping is possible
- Use of machine without dipping process is possible
- Dipping platform 820 x 450 mm
- Heating power 36 kW

- Pneumatic dipping cylinder

S 910 B

Technical details

Chamber size (w x l x h/mm): 1000 x 550 x 200
 Sealing length (mm): 2 x 1000 + 1 x 530
 Distance x (y) (mm): 530 (1000)
 Vacuum pump (cbm/h): 250
 Power connections: 400V/3Ph+N+PE/50Hz
 Power (kW): 12,1
 Compressed air (l/min): 20 at 6 Bar
 Max. bag size (mm): 530 x 1000
 Outer dimensions (w x l x h/mm): 2800 x 1180 x 2055
 Weight (kg): 750

Technical details

Working area (w x l/mm): 820 x 450
 Dipping depth (mm): 100/150/200
 Water volume (l): 140
 Maximum Product weight (kg): 50
 Power connections: 400V/Ph3+N+PE/50Hz
 Power (kW): 37
 Safeguarding (Amp.): 63
 Compressed air (l/min): 25 at 6 Bar
 Outer dimensions (w x l x h/mm): 950 x 890 x 1500
 Weight (kg): 265
 Heating capacity (kW): 36

ST 170

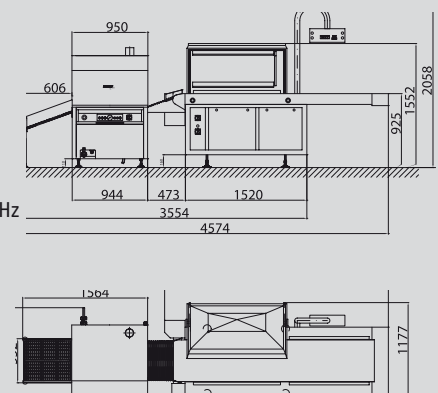

Important: Air pressure connection necessary!



AUTOMATIC DOUBLE CHAMBER MACHINE WITH HOT WATER SHRINK TUNNEL



More information about the machines with application examples and films can be found on our free multimedia CD.

SD 520 B + ST 170

Standard equipment: Stainless steel construction. Each chamber has one stainless steel sealing bar in front 660 mm. Sealing with airpressure support. High efficiency vacuum pump, 250 cbm/h. Cut-off sealing separately adjustable. User friendly waterproove control board. Vacuum controlled by sensor. Automatic lid movement. Conveyors with height adjustment. Soft ventilation. Vacuum stop button. Following options are possible: gas flushing, bi-active sealing, lid height 300 mm.

ST 170: Stainless steel construction. The automatic transport of the product in and out of the shrink tunnel is controlled by a photocell. Water temperature is adjusted with a thermostat. We also offer the following standard equipment: steam exhaust release through the lid, dipping time and dipping depth of water, also time for water to drip from product is adjustable, slight on left side, pneumatic dipping cylinder, automatic filling of water, user friendly construction, easy cleaning, manual dipping is possible, use of machine without dipping process is possible, dipping platform 820 x 450 mm and heating power 36 kW.



	SD 520 B
Technical details	
Chamber size (w x l x h/mm):	800 x 730 x 250 (300)
Usable chamber high (mm):	180 (230)
Sealing length (mm):	2 x 660
Distance x (y) (mm):	730
Vacuum pump (cbm/h):	250
Power connections:	400V/3Ph+N+PE/50Hz
Power (kW):	7,5
Compressed air (l/min):	50 at 6 Bar
Maximum bag (mm):	650 x 800
Outer dimensions (w x l x h/mm):	1625 x 1270 x 1550
Weight (kg):	690

Important: Air pressure connection necessary!

	ST 170
Technical details	
Working area (w x l/mm):	820 x 450
Dipping depth (mm):	100/150/200
Water volume (l):	140
Maximum Product weight (kg):	50
Power connections:	400V/Ph3+N+PE/50Hz
Power (kW):	37
Safeguarding (Amp.):	63
Compressed air (l/min):	25 at 6 Bar
Outer dimensions (w x l x h/mm):	950 x 890 x 1500
Weight (kg):	265
Heating capacity (kW):	36

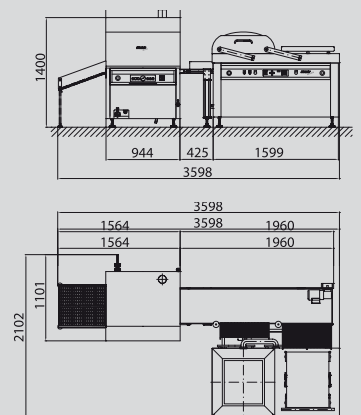

COMPACT THERMOFORMING VACUUM PACKAGING MACHINE



SPRINTER

The new SPRINTER is an unique solution in many ways. It is shorter and more compact than other thermoforming machines without losing important features. With a shortness of only 2,6 m its useable also in very small rooms. In spite of its shortness the SPRINTER has three complete package lengths open for loading the products because of its extremely long loading station. This allows to work utmost rational also with a couple of employees. The SPRINTER guarantees up to 5 times the efficiency and speed of a normal chamber machine. The new lifting unit is reducing the air pressure consumption to a minimum. Therefore the SPRINTER is not only unbeatable in its purchase costs but also in operation cost. It is ready to work and the production can be started immediately after connecting the machine.

COMPLETE LENGTH ONLY 2,6 m



SPRINTER

Technical details SPRINTER

Standard machine shortness (incl. Discharge belt):	2600 (2800) mm
Machine width:	910 mm
Machine height: ± 50 mm	1685 mm
Loading height: ± 50 mm	1000 mm
Top film:	315 mm
Bottom film:	322 mm
Film core:	3", 76 mm
Maximum roll diameter for bottom film:	330 mm
Maximum roll diameter for top film:	330 mm
Index:	240 mm
Max. thermoforming depth:	100 mm
Package dimension with Format 1.1:	internal 260x220 mm
Package dimension with Format 2.1:	internal 120x220 mm
Package dimension with Format 3.1:	internal 73x220 mm

Package dimension with Format 1.2:	internal 260x100 mm
Package dimension with Format 2.2:	internal 120x100 mm
Package dimension with Format 3.2:	internal 73x100 mm
Compressed air consumption according to format and depth:	starting at 7 l/cycle with min. 6 bar
Compressed air connection:	Rectus NG7
Power supply:	400V/3Ph+N+PE/50Hz
Power (kW):	from 5,5
Water connection in and out: :	Rectus NG7
Vacuumpump:	40 cbm/h
Weight with tools:	starting at 1000 kg

Important: Water and air pressure connection necessary!





More information about the machines with application examples and films can be found on our free multimedia CD.

Excellent:

- Special features of the SPRINTER are its compact therefore space saving construction, its high cycle speed and its low purchase costs and running costs (e.g. minimum air pressure consumption)
- A powerful thermoforming machine for medium size companies!
- It is ready to start at the delivery. Just connect it and it is ready to work
- Many advantages because of hydraulic lifting unit:
 - Maintenance free supply of forming and sealing station as well as the cross cutting system
 - High closing force
 - The oil used in the hydraulic unit accords to FDA and USDA guidelines and it is useable in food machineries, clearly as water, odourless, tasteless, eatable, health safe and food harmless

Standard equipment SPRINTER:

- High performance vacuum pump 40 cbm/h from BUSCH
- Film width 322 mm
- Index 240 mm
- Thermoforming from 5 mm to 100 mm adjustable in 5 mm steps
- Thermoforming tools are cooled with water
- Frame sealing
- Longitudinal cutting with rotating round knife
- Cross cutting with knife, hydraulic movement
- Discharge slide
- Vacuum controlled by sensor
- Programmable SPS control system
- 5,7" Touch panel with 256 colours, IP 65, user friendly, multilingual
- 98 user programs adjustable
- Password protection possible
- Certified and approved machine according to CE safety standards that are in line with the CE and European Hygiene and safety guidelines
- Pilz security technology
- Stainless steel switch cabinet IP 65, built according the newest guidelines and technology standards
- 2 separated heating systems for thermoforming and sealing, that can be individually set and programmed with the SPS control system
- Service opening for easy servicing of the vacuum pump
- Easy and safe machine cleaning through a cleaning program
- Service friendly chain tension system
- Easiest lubrication of the chain movement bearings
- Solid transport chain with a reinforced 5/8" configuration
- 6 different steps of Index speed
- Acceleration and slowing down of chain movement in 7 steps changeable (important for liquid products)
- Energy savings through vacuum pump with stand-by function
- Parts from worldwide known manufacturers
- Height adjustable stainless steel feet
- Bottom film holder above forming station

Vario-tool:

With vario-tool, an easy insert system for different products possibilities. Easy and fast change of film rolls and format die sets.

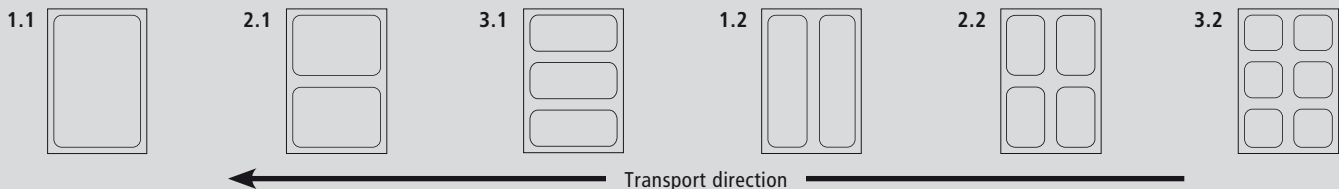

If you need we can also offer:

- Water recirculation cooling system
- Discharge belt
- Gas flushing system for MAP packaging incl. special pressure control system for faster and uniform gas injection
- High performance vacuum pump 63 cbm/h, 100 cbm/h from Busch integrated in machine
- Flexoprint coder with stamping system
- Photo cell for printed top film with print marks incl. Film brake
- Vario-inserts 1.1, 2.1, 3.1, 1.2, 2.2, 3.2
- Product specific insert for forming and sealing station
- For flat products it is possible to limit the movement of the tools from 100 mm to 50 mm to get a higher cycle speed
- Vacuum pump external
- Trim removal suction system
- Trim removal system with roll
- Longer loading station by 480 mm or 960 mm
- Thermo transfer printer or Top film labeller
- Pressure control of gas, air and water supply



THERMOFORMING MACHINES

QUICK-VAC 2000-322

QUICK-VAC 2000-422

Two different thermoforming machines are available which can work in combination with an automatic slicer and a transfer conveyor to complete a fully automatic slicing and packing line. Both thermoforming machines are also available in a longer version (longer loading zone). If hard film is used a punch is available as an option.



Sous-Vide – Cooking in vacuum!
Please find further information on our free DVD. Please request our DVD.

2 DIFFERENT FILM SIZES AVAILABLE



Quick-VAC 2000

- High performance 63 cbm/h vacuum pump
- Thermoforming tools are cooled through water
- Bottom film thermoformed through compressed air
- Total flat sealing with flat sealing plate
- Cross cutting with guillotine, pneumatic system
- Longitudinal cutting with rotating round knife
- Trim removal suction system with strips container
- Discharge slide
- Sealing with compressed air
- Siemens SPS programmable control system with touchscreen
- Film movement controlled through POSI-Stop, which allows exact index positioning
- Certified and approved machine according to CE, EMV and GS safety standards that are in line with the CE and European Hygiene and safety guidelines
- Switch cabinet built according to guidelines
- Pneumatic system for oil free operation
- 2 separated heating systems for thermoforming and sealing, that can be individually set and programmed through the SPS control system
- Solid transport chain with a reinforced 5/8" configuration for all film types
- Big value and pipe diameter for high cycle speed
- Energy savings through vacuum pump with stand-by function
- Parts from worldwide known manufacturers





More information about the machines with application examples and films can be found on our free multimedia CD.

Excellent

- Special features of the proven QuickVac 2000 are its compact therefore space saving construction, its high cycle speed and its low price
- A powerful thermoforming vacuum packaging machine for medium size companies
- QuickVac 2000 guarantees up to 5 times the efficiency and speed of a normal chamber machine. It is ready to start at the first shot. Just connect it and it is ready to work!

The main advantages in a quick glance

- Made in Germany
- Solid stainless steel frame construction
- Easy format change
- Fast film change
- Uncomplicated cleaning process due to flat surface
- Easy and safe machine cleaning through a cleaning position key
- All movable parts maintenance free
- With vario-tool, an easy insert system for different product possibilities

Technical details Quick-VAC 2000:

Standard machine shortness:	2950 mm	Max. thermoforming depth:	Standard: 50 mm/Option: 120 mm
- Filling station 480 mm longer:	3430 mm	Standard package dimension (with 322 mm film width):	internal 270 x 180 x 50 mm external 290 x 200 x 50 mm
- Punch for hard foil:	4000 mm	Standard package dimension (with 422 mm film width):	internal 370 x 180 x 50 mm external 390 x 200 x 50 mm
- Punch and longer loading station:	4500 mm	Maximum package dimension (with 322 mm film width):	internal 270 x 280 x 120 mm external 290 x 300 x 120 mm
Machine width (with 322 mm film width):	770 mm	Maximum package dimension (with 422 mm film width):	internal 370 x 280 x 120 mm external 390 x 300 x 120 mm
Machine width (with 422 mm film width):	870 mm	Cycle speed: according to product:	up to 10 cycles/minute
Machine height: ± 50 mm	1750 mm	Compressed air consumption according to format and depth:	starting at 325 l/min with min. 6 bar
Loading height: ± 50 mm	950 mm	Compressed air connection:	1/4"
Top film width		Power supply:	400 V/3 Ph + N + PE/50 Hz
Vacuum (with 322 mm Bottom film width):	294 mm	Power consumption:	6 kW (6,8/7,5 kW)
Vacuum (with 422 mm Bottom film width):	394 mm	Water connections in:	1/4"
Vacuum + Gas flush (with 322 mm Bottom film width):	315 mm	Water connections out:	1/4"
Vacuum + Gas flush (with 422 mm Bottom film width):	415 mm	Weight with tools:	starting at 1000 kg
Bottom film width:	322 mm or 422 mm		
Film core:	3", 76 mm		
Maximum roll diameter for top and bottom film:	400 mm		
Standard index:	200 mm		
Maximum index:	300 mm		

Vario-tool: With vario-tool, an easy insert system for different product possibilities.

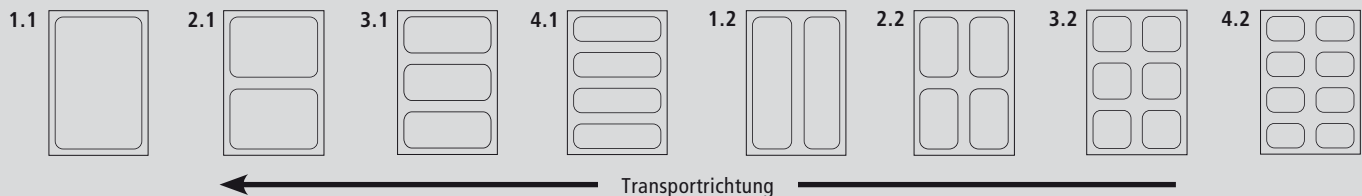

If you need we can also offer

- Water recirculation cooling system
- Discharge Conveyor belt 800 mm or 1200 mm
- Sealing plate for contour sealing
- Gas injection system for MAP packaging incl. special pressure control system for faster and uniform gas injection
- High performance 100 cbm/h, 160 cbm/h vacuum pump
- Flexoprint coder with stamping system, Thermotransfer- or Top film labeller can be install on the machine
- Photocell for printed top film with film brake
- Vario insret with 1.1, 2.1, 3.1, 4.1, 5.1, 1.2, 2.2, 3.2, 4.2, 5.2 formats
- Special insert according to the forming station
- Index up to 300 mm
- External vacuum pump
- Bottom film holder vertical (machine will be longer by 1.000 mm)
- Trim removal system with rolls
- Extension of the loading station by 480 mm, 990 mm or by 1.470 mm
- Punch for hard film, with a special forming insert up to 35 mm deep
- Thermoforming depth up to 100 mm or 120 mm
- Vacuum with sensor
- Control board in a swing arm
- Film width 422 mm
- Film feeding device with rocker arm
- Filmend control
- Cross cutting with incident support
- Longitudinal cutting with squeezing knife



CONTROL BOARD



More information about the machines with application examples and films can be found on our free multimedia CD.

SELECT



Adjustments of sealing and vacuum time by push buttons. Vacuum-Stop-Button. It contains a service program to evaporate the humidity from the pump, oil change display and an operating hours counter. Vacuum pump with continuous running and Cut-off sealing with 1 temperature as well as gas flushing with extra costs optional available.

PERFECT



Sensor-controlled electronic. Adjustments are made with the push of buttons. Vacuum-Stop-Button. 10 user programs can be individually stored. It contains a service program to evaporate the humidity from the vacuum pump, evaporation point control, oil change display, soft venting and an operating hours counter. Vacuum pump with continuous running, password protection and Cut-off sealing with 1 temperature as well as gas flushing and Cut-off sealing with 2 different temperatures with extra costs possible.

Standard Equipment KOMET Vakuum packaging machines:

- Made in Germany
- All stainless steel
- Vacuumstop button
- Parallel sealing
- Automatic lid opening
- Powerful vacuum pump
- Electronic control board

TOUCH TERMINAL: FASTVAC, TS-1000, SPRINTER



Pilz touch terminal PMI, hardware platform for safe automation, all safety-relevant components (e.g. switches) are made by Pilz, user-friendly visualization can be operated intuitively, operational menu including target and actual values, user menu to store 98 programs and a fix standard program, service menu for maintenance and service support such as e.g. film loading program, tool change, cleaning function or pump dehumidification, failure menu including error display and failure history,

maintenance menu for the service technician including parameter settings and manual operation, automatic recognition of the evaporation point, oil change display, cycle counter for product management, password protection, texts of different languages of the countries may be displayed, special equipment can be activated.

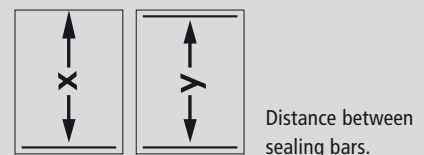
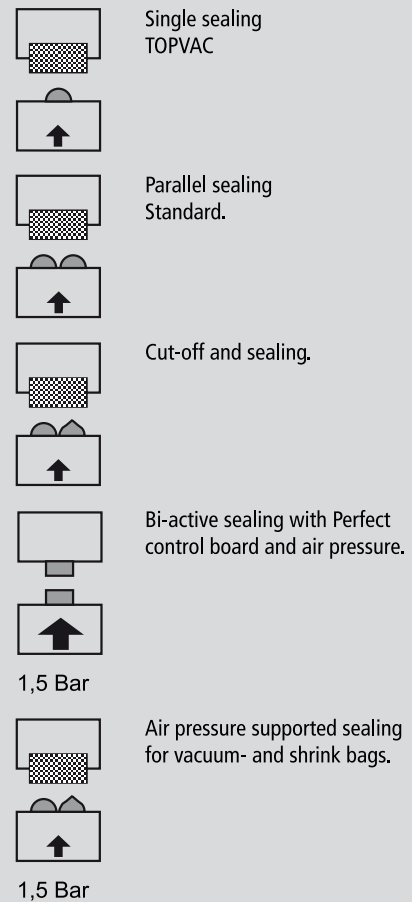

Distance between sealing bars.

More information and animated films about this options and their function you will find on our multimedia CD

